

VIPER®

Remote Start Keyless Entry

Model 5301

Owner's Guide

Directed®
E L E C T R O N I C S

© 2011 Directed Electronics, Vista, CA
G4202V 2011-03

Contents

Government regulations	iii
Warning! Safety first	v
What's included.....	1
Important information	1
Your warranty.....	1
Replacement remote controls	1
Responder LE 2- way remote.....	2
1- way companion remote.....	3
Transmitter configuration.....	4
Control Center	5
Basic commands	6
Lock	6
Unlock.....	6
Remote Start.....	6
AUX	6
Function shift	7
Advanced commands: function level 1	8
Silent lock.....	8
Silent unlock.....	8
Runtime reset.....	8
Aux 1	8
Cabin temperature.....	8
Advanced commands: function level 2	9
Valet mode	9
Timer mode.....	9
Aux 2.....	9
Lock status	9
Advanced commands: function level 3.....	10
Car finder.....	10
Smart start	10
Aux 3.....	10
Runtime check	10
Advanced commands: function level 4.....	11
Rear defogger	11
Aux 4.....	11
Out of range notification.....	12
System maintenance	12
Low battery indicator	13
Configuring your remote	14
Programming	16
Multi-car control capability.....	17

Using your system	19
Locking the vehicle.....	19
Unlocking the vehicle	19
Valet mode	20
Panic Mode	21
Overriding the optional Starter kill	21
Using the remote start.....	22
Manual transmission vehicles	24
Timer mode.....	25
Turbo timer mode.....	26
Smart start activation.....	27
Low runtime alert	28
Cabin temperature.....	28
Turning on the rear defogger.....	29
Pit Stop mode	29
Safety features.....	30
Optional starter anti-grind circuitry.....	30
Disabling the remote start system	30
Remote Start Safe-lock	30
Diagnostics	31
Locking.....	31
Unlocking	31
Remote start	31
Owner recognition	32
Rapid resume logic.....	32
Power saver mode.....	32
Programming options.....	33
Convenience expansions.....	34
Glossary of terms	35
Quick reference guide	37
Limited lifetime consumer warranty	40

Government regulations

This device complies with Part 15 of FCC rules. Operation is subject to the following two conditions: (1) This device may not cause harmful interference, and (2) This device must accept any interference received, including interference that may cause undesirable operation.

This equipment has been tested and found to comply with the limits for a class B digital device, pursuant to Part 15 of the FCC Rules. These limits are designed to provide reasonable protection against harmful interference in a residential installation. This equipment generates and can radiate radio frequency energy and, if not installed and used in accordance with the instruction manual, may cause harmful interference to radio communications. However, there is no guarantee that interference will not occur in a particular installation. If this equipment does cause harmful interference to radio or television, which can be determined by turning the equipment Off and ON, the user is encouraged to try to correct the interference by one or more of the following measures:

- Reorient or relocate the receiving antenna.
- Increase the separation between the equipment and receiver.
- Connect the equipment into an outlet on a circuit different from that to which the receiver is connected.
- Consult the dealer or an experienced radio / TV technician for help.

To satisfy FCC RF exposure compliance requirements, this device should be used in hand-held, hand operated configurations only. The device and its antenna must maintain a separation distance of 20 cm or more from the person's body, except for the hand and wrists, to satisfy RF exposure compliance. This device is designed to be used in a person's hands and its operating configurations do not support normal transmissions while it is carried in pockets or holsters next to a persons' body.

This device complies with the Industry Canada Radio Standards Specification RSS 210. Its use is authorized only on a no-interference, no-protection basis; in other words, this device must not be used if it is determined that it causes harmful interference to services authorized by IC. In addition, the user of this device must accept any radio interference that may be received, even if this interference could affect the operation of the device.

Warning:

Changes or modifications not expressly approved by the party responsible for compliance could void the user's authority to operate this device.

Warning! Safety first

The following safety warnings must be observed at all times:

Due to the complexity of this system, installation of this product must only be performed by an authorized Directed dealer.

When properly installed, this system can start the vehicle via a command signal from the remote control transmitter. Therefore, never operate the system in an enclosed area or partially enclosed area without ventilation (such as a garage). When parking in an enclosed or partially enclosed area or when having the vehicle serviced, the remote start system must be disabled using the installed toggle switch. It is the user's sole responsibility to properly handle and keep out of reach from children all remote control transmitters to assure that the system does not unintentionally remote start the vehicle. **THE USER MUST INSTALL A CARBON MONOXIDE DETECTOR IN OR ABOUT THE LIVING AREA ADJACENT TO THE VEHICLE. ALL DOORS LEADING FROM ADJACENT LIVING AREAS TO THE ENCLOSED OR PARTIALLY ENCLOSED VEHICLE STORAGE AREA MUST AT ALL TIMES REMAIN CLOSED.** These precautions are the sole responsibility of the user.

Remote starters on manual transmission vehicles operate differently than those with automatic transmission because you must leave your car in neutral. You must read this Owner's Guide to familiarize yourself with the proper procedures regarding manual transmission remote starters. If you have any questions, ask your installer or contact Directed at 1-800-753-0600.

Before remote starting a manual transmission vehicle, be sure to:

- Leave the vehicle in neutral and be sure no one is standing in front or behind the vehicle.
- Only remote start on a flat surface
- Have the parking brake fully engaged

Warning! It is the responsibility of the owner to ensure the parking/emergency brake properly functions. Failure to do so can result in personal injury or property damage. We recommend the owner have the parking/emergency brake system inspected and adjusted by a qualified automotive shop biannually.

Use of this product in a manner contrary to its intended mode of operation may result in property damage, personal injury, or death. (1) Never remotely start the vehicle with the vehicle in gear, and (2) Never remotely start the vehicle with the keys in the ignition. The user must also have the neutral safety feature of the vehicle periodically checked, wherein the vehicle must not remotely start while the car is in gear. This testing should be performed by an authorized Directed dealer in accordance with the Safety Check outlined in the product installation guide. If the vehicle starts in gear, cease remote start operation immediately and consult with the authorized Directed dealer to fix the problem.

After the remote start module has been installed, contact your authorized dealer to have him or her test the remote start module by performing the Safety Check outlined in the product installation guide. If the vehicle starts when performing the Neutral Safety Shutdown Circuit test, the remote start unit has not been properly installed. The remote start module must be removed or the installer must properly reinstall the remote start system so that the vehicle does not start in gear. All installations must be performed by an authorized Directed dealer.

OPERATION OF THE REMOTE START MODULE IF THE VEHICLE STARTS IN GEAR IS CONTRARY TO ITS INTENDED MODE OF OPERATION. OPERATING THE REMOTE START SYSTEM UNDER THESE CONDITIONS MAY RESULT IN PROPERTY DAMAGE OR PERSONAL INJURY. YOU MUST IMMEDIATELY CEASE THE USE OF THE UNIT AND SEEK THE ASSISTANCE OF AN AUTHORIZED Directed DEALER TO REPAIR OR DISCONNECT THE INSTALLED REMOTE START MODULE. DIRECTED WILL NOT BE HELD RESPONSIBLE OR PAY FOR INSTALLATION OR REINSTALLATION COSTS.

This product is designed for fuel injected vehicles only. Use of this product in a standard transmission vehicle must be in strict accordance with this guide.

This product should **not** be installed in any convertible vehicles, soft, or hard top with a manual transmission. Installation in such vehicles may pose certain risk.

What's included

- One five-button/2- way Supercode Responder LE remote control
- One five-button/1- way Supercode remote
- The control module (installed out-of-sight)
- Control Center with integrated status LED and Control button
- A remote start defeat toggle switch
- Window decals
- Your warranty registration

Important information

Congratulations on the purchase of your state-of-the-art remote start and keyless entry system. Due to the complexity of this system, it must be installed by an authorized dealer only. Installation of this product by anyone other than an authorized dealer voids the warranty. All dealers are provided with a preprinted dealer certificate to verify authorization.

By carefully reading this Owner's Guide prior to using your system, you will maximize the use of this system and its features. You can print additional or replacement copies of this manual by accessing our web site at www.directed.com.

➤ Your warranty

Your Responder LE system comes with a warranty. Please make sure you receive the warranty registration card and proof of purchase from your dealer indicating the product was installed by an authorized Directed dealer. Your product warranty must be validated within 10 days of purchase. You can validate it online at www.prodregister.com/directed or complete and return the warranty registration card.

➤ Replacement remote controls

Your system comes with one Responder LE remote control (P/N 7251V) and one remote control (P/N 7152V). If additional remotes are desired, please see your authorized dealer or visit www.directedstore.com to order.

Responder LE 2- way remote

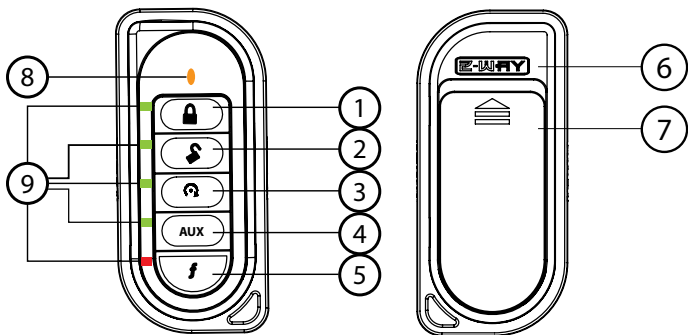

Feature	Description
1	Lock button Press for one second to lock.
2	Unlock button Press for one second to unlock.
3	Remote start button Press for one second to activate remote start.
4	Auxiliary button Press and hold for 1.5 second to activate optional trunk release.
5	Function button Allows access to programming and modifies operation of the other buttons.
6	Label Back of remote has label to identify the remote as 2- way or 1- way.
7	Battery Door Remove to access batteries when necessary. For more detail, see Page 13.
8	Transmit indicator
9	LED indicators Flashes to indicate function confirmation

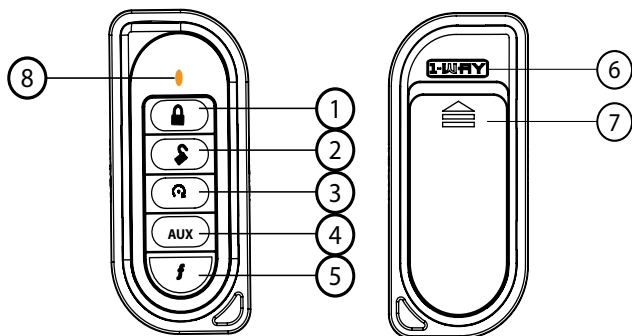

Note: If Keypad Lock is On, press *f* and then press  to unlock.

1-way companion remote



Note: See call-out table for 2-way remote.

➤ Transmitter configuration

		Advanced Commands			
Basic Commands		Function Level 1	Function Level 2	Function Level 3	Function Level 4
Level	Direct Access	f x 1	f x 2	f x 3	f x 4
Button					
	Lock	Silent Lock			
	Unlock	Silent Unlock	Valet Mode	Car Finder	
	Remote Start	Reset Runtime	Timer Mode	Smart Start	Rear Defogger
AUX	Trunk Release	AUX 1	AUX 2	AUX 3	AUX 4
f *	Function Shift**	Cabin Temp. Request** (2- way only)	Lock Status** (2- way only)	Runtime Check** (2- way only)	

*Used to access function levels for Advanced Commands
(**f** with multiplier in third row implies button presses)

** Must be pressed and held to access state

Control Center

The Control Center, typically located on the upper part of the front windshield sends and receives commands or messages to and from your system. It consists of:

- The In-vehicle system antenna, for 2- way communication to the system.
- The Status LED, as a visual indicator of the system's status.
- The Control button, for placing the system into Valet Mode and to perform the Emergency Override operation.

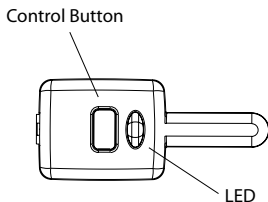

Basic commands

Lock



Command:	Press one time to Lock
Feedback:	Lock LED turns on with 1 beep.
Notes:	Press/hold for 1.5 seconds to Lock the system and then activate the Panic output*

Unlock



Command:	Press one time to Unlock
Feedback:	Unlock LED turns on and remote beeps twice.
Notes:	

Remote Start



Remote Start

Command:	Press one time to activate Remote Start
Feedback:	Remote Start LED turns on, remote start tones.
Notes:	

AUX

AUX

Command:	Press and hold for 1.5 seconds to activate the Trunk Release.
Feedback:	The AUX LED turns on and AUX activation tone sounds.
Notes:	This is an optional feature. See your authorized Directed dealer for details.

Function shift



Function Shift

Command:	Press 1 to 4 times. (See Function shift table.)
Feedback:	LED indicators turn on (according to the feature command)
Notes:	Each Press then release, shifts the function of the command button.

Feedback is available on the 2- way remote only.

*Horn honk is an optional feature. The panic and horn honk feature is available when this option is installed.

Pressing more than one button simultaneously generates an error tone and the Function LED turns on, and all other LEDs flash.

Advanced commands: function level 1

Silent lock

Command: Press **f** one-time and then press .

Feedback: Lock LED turns on.

Notes: Locks the system without horn honks*

Silent unlock

Command: Press **f** one-time and then press .

Feedback: Unlock LED turns on.

Notes: Unlocks the system without horn honks*

Runtime reset

Command: Press **f** one-time and then .

Feedback: Remote start on tones sound, all LEDs light up to indicate start time has been restored.

Notes: Re-starts the runtime counter if remote start is active. If the remote start is not active, the 2-way remote responds with error tone. (see page 23)

Aux 1

Command: Press **f** one time and then press **AUX**.

Feedback: The Aux LED turns on, activation tone sounds.

Notes: This is an optional feature. See your authorized Directed dealer for details.

Cabin temperature

Command: Press **f** one time, then Hold for 1.5 seconds .

Feedback: Cabin temperature is displayed on the remote.

Notes: LED lights turn on to indicate a range. (See page 28)

*Horn honk is an optional feature.

Advanced commands: function level 2

Valet mode

Command: Press **f** two-times and then .

Feedback: Remote beeps 1 to 2 times when entering or exiting Valet Mode and unlock LED turns on.

Notes: To enter or exit Valet mode, even if Locked. When entering Valet Mode the remote beeps one-time. When exiting Valet Mode the remote beeps two-times.

Timer mode

Command: Press **f** two-times and then .

Feedback: Remote start LED turns on, with 1 beep when enabled and 2 beeps for disabled.

Notes: Enables or disables the remote start timer mode. (see page 25)

Aux 2

Command: Press **f** two times and then press **AUX**.

Feedback: The Aux LED turns on, and Aux activation sounds.

Notes: This is an optional feature. See your authorized Directed dealer for details.

Lock status

Command: Press **f** two-times and then hold for 1.5 seconds.

Feedback: Lock or Unlock LED on 2- way remote lights up to display if the system is in locked or unlocked mode.

Advanced commands: function level 3

Car finder

Command: Press **f** three-times and then .

Feedback: The remote emits 1 short beep, the vehicle emits 1 long horn honk*, and the parking lights flash 10 times.

Notes: Lock/Unlock cancels the parking light flashes.

Smart start

Command: Press **f** three-times and then press .

Feedback: Remote start LED turns on, with 1 beep for enable or 2 beeps for disable.

Notes: Enables or disables the Smart Start feature. (see page 27)

Aux 3

Command: Press **f** three times and then press **AUX**.

Feedback: The AUX LED turns on, Aux activation tone sounds

Notes: This is an optional feature. See your authorized Directed dealer for details.

Runtime check

Command: Press **f** three times, and then Hold for 1.5 seconds.

Feedback: Remote start On tones sound.

Notes: Runtime remaining is displayed via LEDs. (See Page 23) If remote start is not active the 2-way responds with an error tone.

Advanced commands: function level 4

Rear defogger

Command: Press **f** four times, and then . (after remote start is on.)

Feedback: Remote start LED turns on, 1 beep.

Notes: Manually turns on the defogger when remote start is on. If remote start is not active the 2-way responds with an error tone. This is an optional feature. See your authorized Directed dealer for details.

Aux 4

Command: Press **f** four times and then press **AUX** .

Feedback: The AUX LED turns on, Aux activation tone sounds

Notes: This is an optional feature. See your authorized Directed dealer for details.

Out of range notification

If a command is issued from the remote, but the remote is beyond the range of the vehicle to receive the command, the remote will respond with an out-of-range notification. If this occurs, the transmit indicator on the remote flashes rapidly, the **f** key LED turns on, and the remote emits the error tone sounds.

Since conditions will vary in different areas (i.e.: Weather, RF interference, etc) range may be affected and require you to be closer to the vehicle for successful transmission.

System maintenance

The system requires no specific maintenance. The 2- way remote uses two CR2016 cell batteries and the 1- way remote uses one CR2032 cell battery. When the battery begins to weaken, the operating range is reduced.

Low battery indicator

When the batteries are low, the 2- way remote emits two groups of beeps, the **f** LED flashes, and additional horn honks are emitted when unlocking. It is time to change the batteries. When the battery is low on the 1- way remote the only indication is additional horn honks emitted when unlocking.

Note: Horn honk is an optional feature.

Battery Replacement

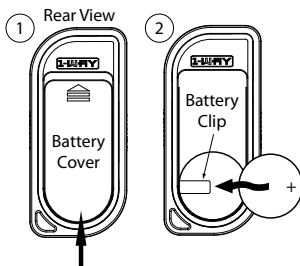

1. Slide the battery cover up by applying equal pressure at its top and bottom (the arrow on the cover indicates the direction), remove the cover from the remote control housing.

2. Gently pry up on the battery to remove it from the holder. Insert a new battery into the holder and under the clip with the positive (+) side up. Replace the battery cover. The remote control is now ready for use.

Configuring your remote

The Responder LE 2- way and 1- way remote controls have menus for programming the remote to the system, and for configuring the remote control user features. Before you start make sure the keypad is unlocked. (See *Button Auto Lock*)

Button Auto Lock

When On, the remote control buttons lock if more than 20 seconds lapses between button presses. If a button is pressed when locked, a fault tone is emitted.

To unlock remote buttons:

Press the **f** button followed by the  button. The remote plays a tone to confirm.

Button Auto Unlocking

After turning the ignition off, the remote unlocks the buttons until the next command is performed. If you do not want Auto Unlocking, it can be turned off by an authorized Directed Dealer.

Button press beep On/Off

Turns On/Off the beeps from the remote when a button is pressed.

Car 2 On or Off

Turns On/Off the Car 2 operation from the remote.

Paging* On or Off, Power Save and Power Save 2

The Responder LE remote monitors your system's messages via Paging.

* This option is not available with the 1- way companion remote.

When Paging is On the remote wakes up every few seconds to detect pages from the system. When Off the remote does not wake up to receive pages from the system.

Power Save extends battery life by turning Paging Off after 72 hours if the remote control is not used during this period. Press any button to resume system monitoring.

Power Save 2 is for maximum battery life and will monitor the system only when remote start has been activated.

Important: When Power Save 2 is on, the optional Factory Alarm trigger messages are not received when remote start is off. (See *Convenience Expansions*)



➤ Programming

To enter: **Hold** the **f** button for 8 seconds, the remote emits one long beep and the transmit LED turns on, the programming main menu has been accessed. If Car 2 mode is on, ignore the car select at 3 seconds.

Remote Features menu

Press and **release** the  button, 2 LED flashes and beeps indicate the remote features menu is accessed and can be set. **Press** buttons indicated below - 1 beep and flash turns the feature on, 2 beeps and 2 flashes turns the feature off.

The paging feature for the 2- way remote has four options: LED On, LED Off, LED flashing or LED flashing in groups of two.

- Keypad Lock: Press  to turn On/Off.
- Remote Beeps: Press  to turn Off.
- Car 2: Press  to turn On/Off.
- Paging (2- way remote only): Press **AUX** to change.

To save and exit, **press** and **release** the **f** button and then press and hold for 1.5 seconds. 1 short and 1 long beep is emitted and the transmit LED turns off when programming is exited.

Remote Pairing

Remote pairing is a process where the Responder LE remote, and the in-vehicle system learn the other's encrypted identification, securing communication between the two from intruders.

Note: Remotes are pre-programmed from the factory.



How to Remote Pair

Make sure the remote control is set for the desired Car 1 or Car 2 operation for the system it is to be paired with.

Placing the system into the remote pair mode:

1. Turn the ignition to the On position.
2. Press, release, then press and hold the Control button (on the Control Center).
3. The Control Center LED begins to flash and the horn honks once to confirm the system is in Pair mode, the Control button can be released. The system will stay in Pair mode for 60 seconds or until the ignition is turned off. The horn will emit one short and one long honk when it exits remote pair mode.

Placing the remote into the remote pair mode:

1. Press and hold the **f** button for 8 seconds. If the transmit LED flashes at 3 seconds, disregard and continue to hold.
2. Wait for the Transmit LED to light solid. Release the **f** button.
3. Press the  button for 1 second. The transmit LED flashes 3 times.
4. Within 5 seconds, press the  button.
5. The vehicle horn honks. You have now successfully learned the remote to the vehicle remote start system.
6. Press the **f** button two times to exit learn routine on the remote. The transmit LED turns off and exit.



➤ Multi-car control capability

You can use the Responder LE 2-way and 1-way companion remote control system for two cars, with full command capability for both vehicles.

While holding a command button and transmitting, the amber LED at the top of the remote control flashes in groups to indicate which car is being controlled.

- Car 1: 1 flash
- Car 2: 2 flashes

To change the Car to be operated:

Press/hold the **f** button for 3 seconds or until the remote beeps and the  and/or  LEDs turn on. This indicates which car the remote currently operates.

- Car 1: 1 beep and Lock LED on
- Car 2: 2 beeps and Lock & Unlock LEDs on

Note: Using the 1-way companion remote, the amber LED flashes and beeps once for Car 1. The amber LED flashes and beeps twice for Car 2.

To change Car while the LEDs are On:

1. Press and release the **f** button. The LEDs will change to indicate the car that can be operated.
2. After you select the car number, press any command button to operate the features. The selected car remains selected until the setting is changed.



Using your system

➤ Locking the vehicle



To lock the vehicle, press the  button on the remote control.



The horn in the vehicle honks one-time, and the parking lights flash one-time. If the power door locks are connected, the doors lock and the optional Failsafe Starter Kill activates. The system automatically checks for errors when it locks. The 2-way remote beeps one-time and then flashes the  LED indicator to confirm locking. If no lock confirmation is received, the remote emits the out-of-range signal.

If errors are found when locking:



If the door is open when you lock the vehicle, the horn honks once and the parking lights flash. The horn then honks a second time to indicate that the door is open and the LED on the Control Center flashes in groups of three. The 2-way remote control sounds a short “error” tone, and the LED indicators next to the  and  buttons flash. **Note:** The optional horn honk and door input must be installed for this feature to work.

Locking without the honk (Silent Lock)

Press the  button on the remote one-time, and then press the  button. The vehicle locks without the confirmation honk. The parking lights flash one-time. The 2-way remote flashes the  LED to confirm locking. If no lock confirmation is received, the 2-way remote emits the out-of-range signal.

Note: When locking in valet mode, the 2-way remote generates a single error tone, and the  and  LEDs light up.

➤ Unlocking the vehicle

Press the  button one time. The vehicle horn honks two-times and the parking lights flash. The 2-way remote beeps two-times and the  LED indicator flashes. If locked the doors unlock and the optional Failsafe Starter Kill deactivates. If no unlock confirmation is received, the 2-way remote emits the out-of-range signal.

UnLocking without the honk (Silent Unlock)

Press the **f** button on the remote one-time, and then press the **S** button. The vehicle unlocks without the confirmation honk. The parking lights flash two-times. The 2- way remote flashes the **S** LED to confirm unlocking. If no unlock confirmation is received, the 2- way remote emits the out-of-range signal.

When unlocking in valet mode with the 2- way remote, the remote generates two error tones and the **S** and **f** LEDs light up.

➤ Valet mode

You can prevent your system from automatically activating the Failsafe® Starter Kill. When the system is in Valet mode, the feature is disabled. The doors do not automatically lock. This is useful when washing or having the vehicle serviced.

To enter or exit valet mode with the Control button:



1. Turn the ignition key on and then off.

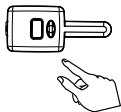

2. At anytime during the next 10 seconds, **press** and **release** the Control button on the Control Center. The LED turns on solid when you enter Valet® Mode, and turns off when you exit Valet Mode.



To enter or exit Valet mode with the remote control:

Press **f** two times, and then **S** to set the system in Valet Mode. Repeat the process to take the system out of Valet Mode.

The Control Center LED turns on solid when in Valet Mode and turns off when exiting Valet Mode.

➤ Panic Mode

If you are threatened in or near your vehicle, you can attract attention by triggering the system with your remote. This feature is only available if the optional horn honk is connected.

- Press  button on the remote for 2 seconds, to enter Panic Mode. The horn honks and the parking lights flash for 30 seconds.
- To stop Panic Mode at any time:
Press  again.

➤ Overriding the optional Starter kill

To bypass the optional Starter kill without a remote control:

Use the button on the Control Center (see diagram below) to bypass the system. You can bypass the system only if you have the vehicle key.

To check proper operation:

1. While the vehicle is locked, open the door. Immediately insert the key into the ignition and turn it to the Run or On position. (all the indicators in the dash turn on)
2. Press and release the Control button one time. The LED on the Control Center will stop flashing and the optional Starter kill is bypassed. You can now start the vehicle with the key.

Note: The override feature allows you to select a specific number of presses needed to disable the system. If the override button has been programmed to a new number of presses by your authorized dealer, that number should be indicated below.

Override button presses _____

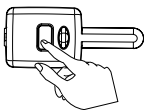

Using the remote start

Read this user guide, including the warnings on page v. at the beginning of the guide before using the remote start. Ensure that the vehicle is parked in an open area, not in a garage. To use your remote start to pre-warm or pre-cool your vehicle, remember to set the climate controls to the desired settings before shutting off the engine.

➤ Remote starting your vehicle

- Press the  button on the remote control. The vehicle parking lights flash.
- On the 2-way remote, the Remote Start LED flashes and ascending Remote Start tone plays.

The preset remote start run time is 12 minutes. This can be changed to between 1 and 60 minutes (see your authorized Directed dealer for programming changes).

Points to remember

If the hood is open or if the brake pedal is pressed, the vehicle will not remote start. **The remote start shuts down:**

- When the brake pedal is pressed
- The hood is opened
- When the remote start command is sent again from a remote control
- When runtime expires

➤ Runtime check

To check the amount of runtime remaining:

After the vehicle is remote started, press the **f** button on the 2-way three-times, and then hold until the remote beeps, and then release. The LEDs light up to indicate how much time is remaining.

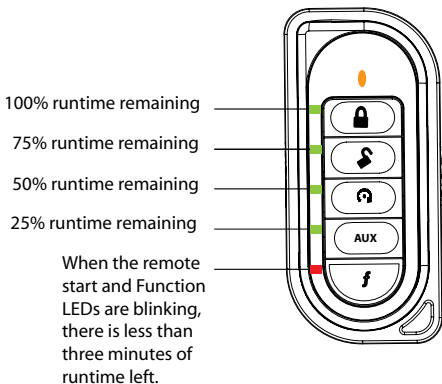

➤ Manual transmission vehicles

When installed into a manual transmission vehicle, the system requires that the MTS mode is properly set when parking. If MTS mode is not properly set or is defeated after being properly set the system will not start the engine.

1. With the engine running, **set** the parking brake and leave the engine running. For Pit Stop or Turbo Timer mode (to leave the engine running after arming) **open** the driver door.
2. **Release** the foot brake (if pressed during Step 1), or **press** and **release** the foot brake anytime. As long as the engine is running there is no time limit to perform this step.
3. Within 20 seconds of foot brake release, **press** any command button on the remote, after 20 seconds return to Step 2 (For Turbo Timer Mode, press the optional dash mounted activation button, or send the Timer Mode command from the Advanced Start menu).
4. The vehicle lights flash 5 times to confirm MTS mode enable and the remote start activates the ignition outputs.
5. **Turn Off** and **remove** the key from the ignition switch, the engine remains running.
6. **Exit** the vehicle, **close** all the doors and **lock** the system.
7. The engine turns off after a few seconds. If the door is opened in Step 3 then the engine continues to run.
You can now remote start the vehicle. If a door is opened before the next remote start activation, the system will not remote start the vehicle.

To drive your automatic or manual transmission vehicle after it has been remote started:

1. Get in without stepping on the brake.
2. Insert the ignition key and turn it to the On position.
3. Now, step on the brake. The remote start turns off.
The vehicle is ready to drive.

➤ Timer mode

This unit can be programmed to start and run the engine every three hours, for a maximum of six cycles. The engine will run for the programmed run time and then shut down. After three hours, the system will restart the engine.

Note: This feature works only when the system has been locked with the remote.

Important: Timer Mode should be used in open areas **only**. Never start and run the vehicle in an enclosed space such as a garage or carport.

To activate timer mode with an automatic transmission:

1. Press **f** twice and then press .
2. The parking lights quickly flash four times to confirm timer mode entry. (The vehicle will not remote start at this point.)
3. The vehicle begins the timer mode sequence.

To activate timer mode with a manual transmission:

1. Enter the MTS mode.
2. Exit the vehicle and lock the system.
3. Enter the timer mode. The parking lights quickly flash 4 times to confirm entry into timer mode (vehicle will not remote start at this point). The vehicle begins the timer mode sequence.

Timer Mode is exited automatically after the sixth run cycle. The parking lights slowly flash 4 times when exiting timer mode.

To exit timer mode with the transmitter:

- Press the **f** button twice and then press . The parking lights flash slow four times to confirm timer mode is exited.

To exit timer mode without the transmitter:

1. Make sure the remote start system is not operating the engine.
2. Turn the ignition on. Timer Mode is exited and the parking lights flash slowly four times.

Note: Your authorized Directed dealer using the Bitwriter® programming tool can change the amount of times the remote start activates, and change the intervals between activations in timer mode.

➤ Turbo timer mode*

Turbo timer mode keeps the engine running after arriving at your destination for a programmable period of 1, 3, 5 or 10 minutes. This allows the system's timer to conveniently cool down the turbo after you have left the vehicle. Turbo timer mode can be activated by the remote or optional dash mounted activation button.

To activate turbo timer mode with automatic transmission:

1. While the vehicle is running, press **f** button 2-times, and then press  button. Or you can press the optional dash mounted activation button one time. The vehicle lights turn on and the remote start activates the ignition outputs. The parking lights flash one-time confirming that the remote start is activated.
2. Turn Off the ignition. The car remains running.
3. Exit the vehicle and Lock the system. The vehicle remains running for the programmed run time.

*Must be turned on by an authorized Directed dealer.

To activate turbo timer mode with a manual transmission:

Perform the manual transmission procedure (See page 24) with the door open. Transmit the timer mode feature by pressing **f** two-times, and then press . Or press the optional dash mounted activation button one time. The lights turn on and the remote start activates the ignition.

After exiting the vehicle, lock the system. The vehicle remains running for the programmed runtime. (The remote start feature is still enabled).

You can still remote start the vehicle after the turbo timer has timed out and shut Off the vehicle. For safety reasons, if a door is opened (while the system is Locked or Unlocked) while you are away, the remote start exits the manual transmission mode and will not remote start until the MTS sequence is re-initiated.

➤ Smart start activation

Smart Start uses the hours and cycles settings used in Timer Mode, in addition to temperature or voltage, to automatically start the engine. Activation begins the countdown timer. When the timer expires the vehicle interior temperature is checked and, if it exceeds the temperature or voltage thresholds the engine starts. When the Remote start runtime expires the engine shuts off and the countdown timer restarts. Smart Start is exited after the final start.

Note: This feature works only when the system has been locked with the remote.



The factory setting for temperature high is 100°, and the low is 0° (F). The voltage setting is 10.5v. These settings can be adjusted, or turned off by your authorized Directed dealer using the Bitwriter.

To activate Smart Start mode:

- Press the **f** button on the remote 3 times and then press the  button.

The parking lights flash 5 times **fast** to confirm the remote is in Smart Start mode.

To activate Smart Start mode with a manual transmission:

1. Enter the MTS procedure.
2. Exit the vehicle and press the  button on the remote (the vehicle shuts down when locking).
3. Press the **f** button on the remote 3 times and then press the  button. The parking lights flash 5 times **fast** to confirm the remote is in Smart Start mode.

Use one of the below methods to exit Smart Start mode:

- Perform the same steps you followed to activate Smart Start mode
- Turn the ignition On
- Press the brake pedal

The parking lights flash 5 times **slowly** to confirm the remote has exited Smart Start mode.

➤ Low runtime alert

During remote start a message is sent three minutes before and then again at one minute before the engine turns off. The 2- way remote plays tones as an alert to reset the runtime if desired.

➤ Cabin temperature

Using the Responder LE you have the ability to check the temperature inside the vehicle.

Press the **f** button one-time, and then press and hold until the remote beeps, and then release. The LEDs light up indicating the temperature range of the vehicle.

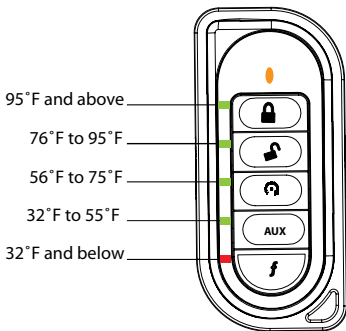

➤ Turning on the rear defogger

The rear defogger (if connected) is programmed to automatically activate when remote start is turned on. If the interior cabin temperature is above 55° F the defogger will not activate.

To manually activate the rear defogger after remote start is on:

- Press **f** four times, and then press . The parking lights flash 3 times to confirm the defogger activation.
During the next remote start activation, the defogger activation resumes normally.

➤ Pit Stop mode

The Pit Stop mode feature allows the vehicle to remain running after the key has been removed from the ignition. This feature is useful for occasions when you want to exit and lock the vehicle for short periods of time, but would like to leave the motor running and the climate controls on.

To perform Pit Stop mode:

1. Before turning Off the engine, press and release the  button on the transmitter.
The parking lights flash one time to confirm that Pit Stop mode has been initiated, then wait a few seconds.
2. Turn the ignition key to the Off position (The engine remains running).
3. Exit the vehicle and lock the system with the remote.
The engine runs until the pre-programmed time elapses or a shut-down input is received.

Note: To use Pit Stop mode with a manual transmission, open the door when going into MTS mode. The parking lights flash five-times to confirm entry into Pit Stop mode. After you exit the vehicle you can lock the system with the remote and the car remains running. If the vehicle shuts down when locking, then the unit did not enter the Pit Stop mode.

Safety features

This system has several important safety features to ensure proper operation of the motor and prevent accidental damage to the engine or its components.

➤ **Optional starter anti-grind circuitry**

Whenever the vehicle is remote started, advanced anti-grind circuitry prevents the starter from engaging, even if the key is turned to the start position. This prevents damage to the starter motor if the key is turned to the start position during remote start operation.

Note: Anti-grind circuitry only works when the remote start system is operating the motor and the optional Failsafe® Starter Kill relay is installed.

➤ **Disabling the remote start system**

This feature allows the remote start unit to be temporarily disabled to prevent the vehicle from being remote started accidentally. This feature is useful when the vehicle is being serviced or stored in an enclosed area.

To disable the remote start, move the shutdown toggle switch to the Off position. Check with your installer for the location of the shutdown switch.
Location of Shutdown Switch _____

➤ **Remote Start Safe-lock**

Remote start safe-lock makes sure the doors are locked when Remote Start is activated and after it is deactivated, even if they are unlocked when remote start is activated. Door locks may require additional parts and labor.

Diagnostics

The microprocessor at the heart of the system is constantly monitoring the switches that are connected to the main unit.

➤ Locking

If the system is locked at the same time that the door input is active, you will hear one horn honk to indicate locking, and then a second horn honk to indicate Bypass Notification.

Note: Bypass Notification does not occur if the optional horn and door input is not installed or when the system is in Silent Mode or if the notification honks have been programmed Off by the installer.

➤ Unlocking

Extra honks when unlocking the system is a notification that the battery in the remote is low and needs to be replaced.

Important: The optional horn honk feature must be installed.

➤ Remote start

This system can provide you with information to indicate what the problem is when using the remote start. When the remote start is activated and fails to engage, count the parking light flashes to determine the problem. The parking lights will flash between 5 - 8 times to indicate what caused the no start situation.

- 5 flashes: brake wire is active
- 6 flashes: hood pin is active
- 7 flashes: manual transmission mode is enabled and not initialized
- 8 flashes: neutral safety wire has no ground or the remote start defeat toggle switch is off.

Keep a record of the number of flashes, to assist your authorized Directed dealer when taking the vehicle in for service.

Owner recognition

Owner recognition lets up to four users of the system have unique settings to meet their specific needs. It is almost like having four separate systems in your vehicle, one for each user. This feature is only available to authorized dealers using the Bitwriter programming tool.

Rapid resume logic

This Directed system will store its current state to non-volatile memory. If power is lost and then reconnected the system will recall the stored state from memory.

For example, if the unit is in Valet Mode and the battery is disconnected for any reason, such as servicing the car, when the battery is reconnected the unit is still in Valet Mode. This applies to all states of the system including lock or unlock.

Power saver mode

Your system will automatically enter Power Saver Mode while locked or in Valet Mode, after a period of time in which no operation has been performed. This lowers the current draw on the vehicle's battery. Power Saver Mode takes over under the following conditions:

Power Saver when the system is locked: After the system has been Locked for 24 hours the status LED on the Control Center flashes at half its normal rate, decreasing the system's current draw.

Power Saver in Valet Mode: When the system enters Valet Mode the Status LED on the Control Center illuminates steadily. If the vehicle is not used (ignition is not turned on) for a one-hour period while the system is in Valet Mode, the status LED shuts Off. If the system remains in Valet Mode, the LED comes back on the next time the ignition is turned On, and then Off.

Programming options

Your system has many custom programmable options. Some may require installation labor. Ask your authorized dealer for details.

The following is a list of the programmable options, with the factory settings in **Bold**.

- **Active** locking (remote only) passive locking, the system automatically locks the doors 30-seconds after the last door is closed; or Auto Re-lock automatically re-locks the doors 60 seconds after unlocking (if no door is opened).
- Locking/Unlocking with horn honk confirmations **On** or **Off**.
- Ignition controlled door lock feature **On** or **Off**: When this feature is programmed on, the doors lock three seconds after the ignition is turned on, and unlock when the ignition is turned Off. The ignition lock and unlock are independent features that can be programmed separately.
- **Panic mode enabled**/disabled when the ignition is turned on or completely turned Off.
- **Comfort closure** is a programming option which closes the vehicle's windows after remote locking. **Note:** Comfort closure can only be used on cars that have the capability of closing the windows (and on some cars the sunroof as well) with the key cylinder in the door.
- Auto re-locking **On/Off**, ensures the vehicle stays locked if it is not entered after unlocking by remote control. After unlocking by remote, the system automatically re-locks locks the doors in 30 seconds. Open any point of entry to stop the re-lock until the next unlock by remote.
- One-time Bypass **On/Off**, can be used to temporarily bypass the Passive locking operation for one cycle. It also bypasses the comfort closure and auxiliary channel outputs programmed to activate when locking. After the next unlock all operations return to normal.

Turn the ignition **On** for one to three seconds and then **Off**. The horn honks once to confirm one-time bypass is enabled.

Convenience expansions

Listed below are some of the expansion options available. Please consult your dealer for a complete explanation of all the options available to you.

Power Trunk Release: The accessory output of the system can operate a factory power release for the vehicle's trunk or hatch. Sometimes an optional relay is required. If the factory release is not power-activated, Directed®'s 522T trunk release solenoid can often be added.

Power Window Control: Automatic power window control is provided with the 529T and 530T systems. These can operate power windows, and can roll them up automatically when the system is Locked, roll them down, or both up and down.

Driver Door Priority Unlocking: The door unlocking operation can be configured to emulate an OEM style of driver priority unlocking for added security during disarming.

Auxiliary Channels: The Auxiliary Channel outputs can be used to activate many of the convenience features found in today's vehicles. The installer can tell you if any the features listed below are compatible with your vehicle.

- Trunk Release
- Windows open/close
- Left Sliding door open/close
- Right Sliding door open/close
- Rear Hatch open/close
- Sunroof open/close
- Audio System on/off
- Headlights on/off

Glossary of terms

Control Center: The Control Center contains the system's radio-frequency antenna, the Control button, and the Status LED. For maximum remote-control range, the Control Center is usually located at the top of the windshield, centered near the rear-view mirror.

Control Module: The "brain" of your system. Usually hidden underneath the dash area of the vehicle. It houses the microprocessor which monitors your vehicle and controls all of the system's functions.

Failsafe® Starter Kill (if equipped): An automatic switch controlled by the system which prevents the vehicle's starter from cranking whenever the system is locked. The vehicle is never prevented from cranking when the system is unlocked in Valet® Mode, or should the Starter Kill switch fail. Your system is ready for this feature, however installation of this feature may require additional labor.

Input: Any physical connection to the system. An input can be provided by existing systems in the vehicle, such as ignition or courtesy lights.

In-vehicle status LED: A light used to indicate the status of your system. It is located on your systems Control Center.



MTS: Manual transmission start. Procedure required for using the remote start in a vehicle with a manual transmission.

RF: Radio frequency

Control Button: A small push button switch located on your systems Control Center. It is used to override the starter interrupt when a remote is lost or damaged, or to enter or exit Valet Mode.



Quick reference guide



- **Locking**
To lock press  for one second. The doors lock. The LED on the Control Center flashes and the horn honks one time. (if connected). The parking lights flash once to confirm locking.
- **Unlocking**
To unlock press . The doors unlock, and the horn honks (if connected) two times. LED on the Control Center stops flashing. The parking lights flash two times to confirm unlocking.
- **Bypassing the optional Starter Kill without a remote**

Turn on the ignition. Press and release the Control button within 15 seconds.

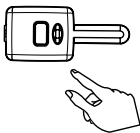

The system should now bypass. If it does not, you may have waited too long or pressed the button incorrect number of times.





Number of Control button presses for disabling _____

- **Silent Lock**
Press **f** one-time and then press . The doors lock. The LED on the Control Center flashes and the parking lights flash once to confirm locking.
- **Silent UnLock**
Press **f** one-time and then press  for one-second. The doors unlock the parking lights flash twice to confirm unlocking.



- Remote Start
Press . The parking lights turn on (if connected). The vehicle starts and runs for the programmed duration.
- Rear Defogger
Press **f** four-times, and then press  (only after remote start is on.) The parking lights flash 3 times confirming activation of the defogger output. This is an optional feature.
- To disable the remote start system
Move the shutdown toggle switch to the Off position.

Location of Shutdown Toggle Switch _____

- Valet Mode
Press **f** two-times and then . The LED on the Control Center comes on solid to indicate the system is in valet. The same sequence on the remote can be used to exit valet mode. The LED turns off when valet mode is exited.
- Pit Stop mode
 1. Before turning Off the engine, press and release the  button. Then wait a few seconds.
 2. Turn the ignition key to the Off position.
 3. Exit the vehicle and lock the doors with the remote.
The engine will remain running until the programmed time elapses or a shut-down input is received.

Cut along the dotted line and fold to keep in purse or wallet for a quick and easy reference.



Limited lifetime consumer warranty

Directed Electronics. ("Directed") promises to the original purchaser to repair or replace (at Directed's election) with a comparable reconditioned model any Directed unit (hereafter the "unit"), excluding without limitation the siren, the remote transmitters, the associated sensors and accessories, which proves to be defective in workmanship or material under reasonable use during the lifetime of the vehicle provided the following conditions are met: the unit was purchased from an authorized Directed dealer, the unit was professionally installed and serviced by an authorized Directed dealer; the unit will be professionally reinstalled in the vehicle in which it was originally installed by an authorized Directed dealer; and the unit is returned to Directed, shipping prepaid with a legible copy of the bill of sale or other dated proof of purchase bearing the following information: consumer's name, telephone number and address; the authorized dealers name, telephone number and address; complete product description, including accessories; the year, make and model of the vehicle; vehicle license number and vehicle identification number. All components other than the unit, including without limitation the siren, the remote transmitters and the associated sensors and accessories, carry a one-year warranty from the date of purchase of the same. ALL PRODUCTS RECEIVED BY DIRECTED FOR WARRANTY REPAIR WITHOUT PROOF OF PURCHASE WILL BE DENIED. This warranty is non-transferable and is automatically void if: the original purchaser has not completed the warranty card and mailed it within ten (10) days from the date of purchase to the address listed on the card; the unit's date code or serial number is defaced, missing or altered; the unit has been modified or used in a manner contrary to its intended purpose; the unit has been damaged by accident, unreasonable use, neglect, improper service, installation or other causes not arising out of defects in materials or construction. The warranty does not cover damage to the unit caused by installation or removal of the unit. Directed, in its sole discretion, will determine what constitutes excessive damage and may refuse the return of any unit with excessive damage.

TO THE MAXIMUM EXTENT ALLOWED BY LAW, ALL WARRANTIES, INCLUDING BUT NOT LIMITED TO EXPRESS WARRANTY, IMPLIED WARRANTY, WARRANTY OF MERCHANTABILITY, FITNESS FOR PARTICULAR PURPOSE AND WARRANTY OF NON-INFRINGEMENT OF INTELLECTUAL PROPERTY, ARE EXPRESSLY EXCLUDED; AND DIRECTED NEITHER ASSUMES NOR AUTHORIZES ANY PERSON OR ENTITY TO ASSUME FOR IT ANY DUTY, OBLIGATION OR LIABILITY IN CONNECTION WITH ITS PRODUCTS. DIRECTED DISCLAIMS AND HAS ABSOLUTELY NO LIABILITY FOR ANY AND ALL ACTS OF THIRD PARTIES INCLUDING ITS AUTHORIZED DEALERS OR INSTALLERS. DIRECTED SECURITY SYSTEMS, INCLUDING THIS UNIT, ARE DETERRENTS AGAINST POSSIBLE THEFT. DIRECTED IS NOT OFFERING A GUARANTEE OR INSURANCE AGAINST VANDALISM, DAMAGE OR THEFT OF THE AUTOMOBILE, ITS PARTS OR CONTENTS; AND HEREBY EXPRESSLY DISCLAIMS ANY LIABILITY WHATSOEVER, INCLUDING

WITHOUT LIMITATION, LIABILITY FOR THEFT, DAMAGE AND/OR VANDALISM. THIS WARRANTY DOES NOT COVER LABOR COSTS FOR MAINTENANCE, REMOVAL OR REINSTALLATION OF THE UNIT OR ANY CONSEQUENTIAL DAMAGES OF ANY KIND. IN THE EVENT OF A CLAIM OR A DISPUTE INVOLVING DIRECTED OR ITS SUBSIDIARY, THE VENUE SHALL BE SAN DIEGO COUNTY IN THE STATE OF CALIFORNIA. CALIFORNIA STATE LAWS AND APPLICABLE FEDERAL LAWS SHALL APPLY AND GOVERN THE DISPUTE. THE MAXIMUM RECOVERY UNDER ANY CLAIM AGAINST DIRECTED SHALL BE STRICTLY LIMITED TO THE AUTHORIZED DIRECTED DEALER'S PURCHASE PRICE OF THE UNIT. DIRECTED SHALL NOT BE RESPONSIBLE FOR ANY DAMAGES WHATSOEVER, INCLUDING BUT NOT LIMITED TO, ANY CONSEQUENTIAL DAMAGES, INCIDENTAL DAMAGES, DAMAGE TO VEHICLE, DAMAGES FOR THE LOSS OF TIME, LOSS OF EARNINGS, COMMERCIAL LOSS, LOSS OF ECONOMIC OPPORTUNITY AND THE LIKE. NOTWITHSTANDING THE ABOVE, THE MANUFACTURER DOES OFFER A LIMITED WARRANTY TO REPLACE OR REPAIR THE CONTROL MODULE SUBJECT TO THE CONDITIONS AS DESCRIBED HEREIN. THIS WARRANTY IS VOID IF THE UNIT HAS NOT BEEN PURCHASED FROM DIRECTED, OR AN AUTHORIZED DIRECTED DEALER, OR IF THE UNIT HAS BEEN DAMAGED BY ACCIDENT, UNREASONABLE USE, NEGLIGENCE, ACTS OF GOD, NEGLIGENCE, IMPROPER SERVICE, OR OTHER CAUSES NOT ARISING OUT OF DEFECT IN MATERIALS OR CONSTRUCTION.

Some states do not allow limitations on how long an implied warranty will last or the exclusion or limitation of incidental or consequential damages. This warranty gives you specific legal rights and you may also have other rights that vary from State to State.

This warranty is only valid for sale of product(s) within the United States of America. Product(s) sold outside of the United States of America are sold "AS-IS" and shall have NO WARRANTY, express or implied. This product may be covered by a Guaranteed Protection Plan ("GPP"). See your authorized Directed dealer for details of the plan or call Directed Customer Service at 1-800-876-0800.

Make sure you have all of the following information from your authorized Directed dealer:

A clear copy of the sales receipt, showing the following:

- o Date of purchase
- o Your full name and address
- o Authorized dealer's company name and address
- o Type of alarm installed
- o Year, make, model and color of the automobile
- o Automobile license number
- o Vehicle identification number
- o All security options installed on automobile
- o Installation receipts

920-0003 06-06

The company behind this system is Directed Electronics

Since its inception, Directed Electronics has had one purpose, to provide consumers with the finest vehicle security and car stereo products and accessories available. The recipient of nearly 100 patents and Innovations Awards in the field of advanced electronic technology.

Directed is ISO 9001 registered.

Quality Directed Electronics products are sold and serviced throughout North America and around the world.

Call (800) 274-0200 for more information about our products and services.

Designed and Engineered in the USA

Directed[®]
E L E C T R O N I C S

G4202V 2011-03

Vista, CA 92081
www.directed.com

© 2011 Directed Electronics—All rights reserved